

# T-Bird Topics

*The official publication of the*

Water Wonderland Thunderbird Club

*Established 1981*

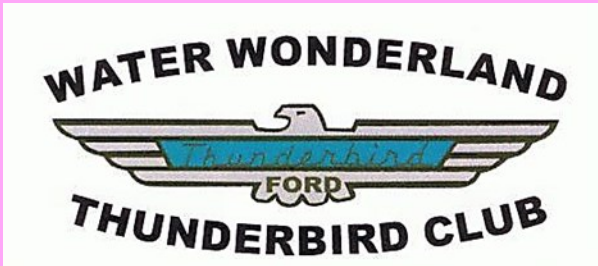

April 2026

Volume 45 Issue 4

## President's Message...

We had a great tour of the newly renovated Michigan Central Train Station. Ford Motor Company spent nearly one billion dollars bringing the old historic landmark back to life. Afterwards, 29 of us went to McShanes Irish Pub in historic Corktown. A great day to see the renovations taking place all over Detroit! Thank you to **Barry** and **Nancy** for organizing this event.

Let's enjoy the spring weather with another day trip adventure!

Get ready for our outing this month as we take a day trip to the famous Millbury Car Museum just over the border in Ohio. The Maumee Valley Thunderbird Club will be joining us and we hope many of our new members from TARTC will join us too. Think about car pooling too.

Please also check the calendar for a full lineup of upcoming events—there's something for everyone!

Thank you to everyone that renewed your dues in the Water Wonderland Thunderbird Club. We are now the largest Thunderbird Club in Michigan and we have a lot planned for 2026. The new directory will be published in April and you will receive an electronic copy. Because of the number of members in the directory, a printed copy will be available upon request only.

In the coming weeks, we'll be sharing information about our 2026 Automotive Tech Scholarship program. Currently, we proudly award two \$1,000 scholarships—one to a student from Wayne-Westland Community School District and one to a student from Plymouth-Canton Community Schools. The Board is also considering adding a third scholarship this year, potentially in Oakland County or Washtenaw County.

We'd love to hear your thoughts as we continue growing this meaningful program. Here's to an exciting year ahead!



## Happy Easter!

*Get the most out of this newsletter. Take a moment to read every page!*

*See you all soon in your Thunderbird, President Barry*

Visit: [www.MichiganTbirds.org](http://www.MichiganTbirds.org) · WWTC · P.O. Box 51027 · Livonia, MI 48151 · 586.703.4435

## Club Events 2026

**April 26<sup>th</sup>** - Milbury Classic Car & Truck Museum, Milbury, OH. *See flyer*

**May 30<sup>th</sup>** - Spring Dust Off *flyer coming*

**June 14<sup>th</sup>** - Bakers Car Show

**July 19<sup>th</sup>** - WWTC Club Picnic

**August 9<sup>th</sup>** - Pre- Woodward Dream Cruise

**September 20<sup>th</sup>** All T-Bird Day

**October 18<sup>th</sup>** - Hines Park Cider Cruise

**November 7<sup>th</sup>** - 2027 Planning Meeting

**December 6<sup>th</sup>** - Annual Club Holiday Party

**Event Details and Other Car Events Will be in the Newsletter**

### Weekly Car Shows!

Monday Nights-Belleville, Main, 5pm-7:30pm, Memorial Day-End of September

Thursday Nights- Ypsi, N River & E Cross, Depot Town, 4-8pm Mem Day -Labor Day

Thursday Nights- Romulus, Eureka & Huron River Dr, Blue Sky (ice cream) 4-7:30pm

Friday Nights- Riverview, Fort Street & Sibley, 4PM -dark (May-Oct)

## Other Great Events

May 17<sup>th</sup>—T-Bird Appreciation Day

May 29<sup>th</sup>—Dinner & Play at Meadowbrook

June 6<sup>th</sup>—Back to the Bricks

June 13<sup>th</sup>—Maumee- Valley Picnic

June 20-21—Motor Muster

June 20<sup>th</sup>—Down River Cruise

June 20<sup>th</sup>—Canton Car Show

June 27<sup>th</sup>—Chelsea Car Show

July 11<sup>th</sup>—Cruise US-12, Wayne

July 11<sup>th</sup>—Grosse Ile car show

August 1<sup>st</sup>—Bladow's *See July Flyer*

August 17<sup>th</sup>—Hines Park Cruise

August 2<sup>nd</sup>—Troy Traffic Jam

Sept tbd—Old Car Festival

Sept 9-13<sup>th</sup>—Flagstaff, AZ

Know  
of  
An Event  
We'd like?

Watch for details in upcoming issues.

Water Wonderland Thunderbird Club presents

## Millbury Classic Cars & Trucks Museum

26929 Cummings Road Millbury, OH 43447

Sunday, April 26, 2026

2:00 PM—4:00 PM



Dinner afterwards at:

### Bob Evans Restaurant

435 Lemoyne Road  
Northwood, Ohio 43619



R.S.V.P to JoAnn at  
JoAnnbill801@comcast.net or  
text names to 248.719.0160 by April 20th

# Thunderbird Appreciation Day

May 17th, 2026

Meet at Parr Park –

in Hines Park at Telegraph – **1:30PM**

Cruise thru Hines Park **2:15PM**

Dinner **3:00 PM**

The Menu will include:

- Angus Burger with Fries
- Warmed Grilled Chicken Salad
- Mac & Cheese
- Turkey Reuben with Fries
- Pulled Pork with Fries

Please RSVP to JoAnn and mail your check for \$25.00 pp to WWTC, P.O. Box 51027, Livonia, Mi 48151 to arrive by May 14, 2026

*Dinner at the*

**Deadwood Grill**  
**1837 Northville Rd.**  
**Northville, MI.**

Deadwood has a “one check rule” so we will have a selected menu of 5 choices and each participant will pay \$25.00 (in advance) covering the meal with coffee, pop, tea and water included. This will also cover the tax and tip. There will be a cash bar to be paid by person ordering from bar.

## GET YOUR MOTOR RUNNIN’

# Bird Talk



## Happy Birthday Members!

3	Roger Hayman	17	Tony Murinas
12	Larry Gruber	17	Sharyn Mannino
12	Jeannie Lieblich	27	Warren Musson
15	George Breil	27	John Norian
15	Harold Wagner	27	Bryan Williams
16	George Roscoe		

April



## In Memoriam..

## Welcome! New Members

**Susan Baxter and James Baker**, [sue.baxter77@yahoo.com](mailto:sue.baxter77@yahoo.com)  
**Teresa Boegler**, [teresab.edv@gmail.com](mailto:teresab.edv@gmail.com)  
**Chuck and Karen Hatcher**, [signtist00@yahoo.com](mailto:signtist00@yahoo.com)  
**Brad and Kathleen Nolan**, [1978umd@gmail.com](mailto:1978umd@gmail.com)

Car models will be published in the new directory

## Something to Sell or Trade?

**2002 Thunderbird Press Kit/Customer Gift Pack.** Five boxes of promo material including die cast of 2002 Tbird. Hardly ever touched—in excellent condition \$400.00. Call Charlie Henry, [Cmhenry57@outlook.com](mailto:Cmhenry57@outlook.com). 248.476.1668



## Classic Thunderbird Maintenance Tech-Tips Cont.

The subject of this month's tech-tip is how to install a back-up electric fuel pump for your Thunderbird.

### Typical Fuel System For 1958-'82 Thunderbird

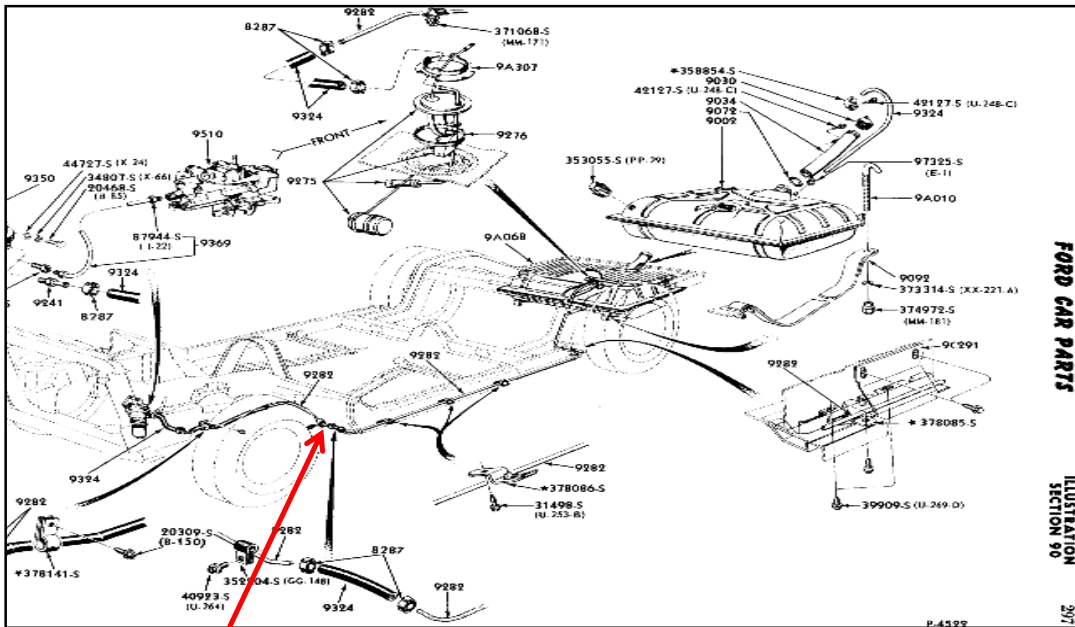

Recommended location for installing a back-up electric fuel pump on 1958-'82 Thunderbirds using the existing fuel hose junction. Option (1) shown below is a setup that provides immediate fuel flow when needed it "primes" your mechanical pump. Wire the electric pump (with a fuse) to a separate switch under the dash.

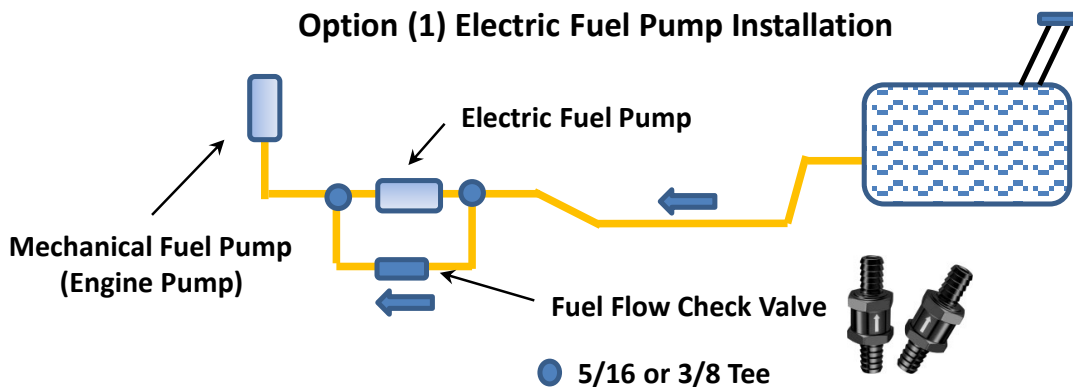

## Classic Thunderbird Maintenance Tech-Tips Cont.

The subject of this month's tech-tip is how to install a back-up electric fuel pump for your Thunderbird.

**Typical Fuel System For 1955-'57 Thunderbird**

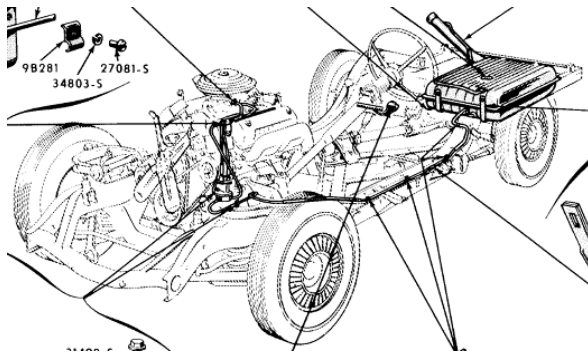

**Typical Fuel System For 1958-'82 Thunderbird**

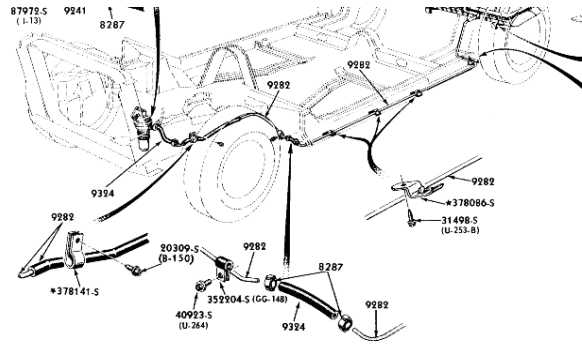

### Option (1) Electric Fuel Pump Installation

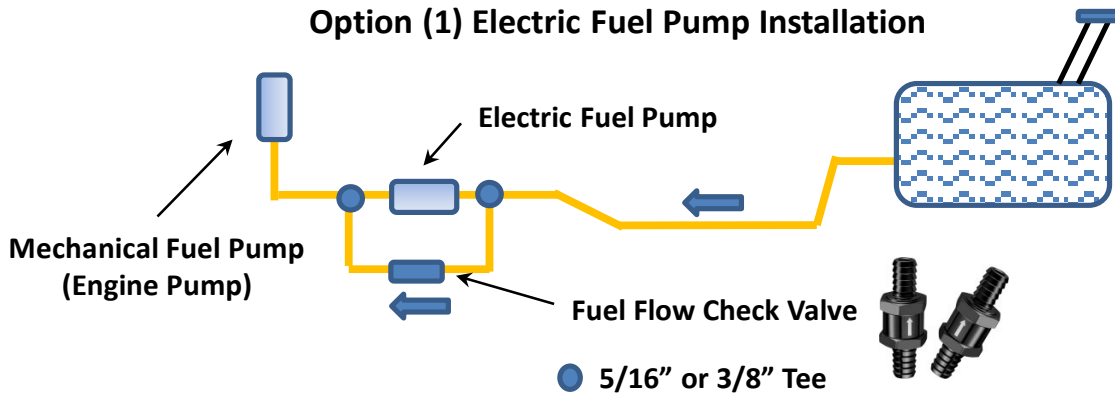

### \*Option (2) Electric Fuel Pump Installation More Flow

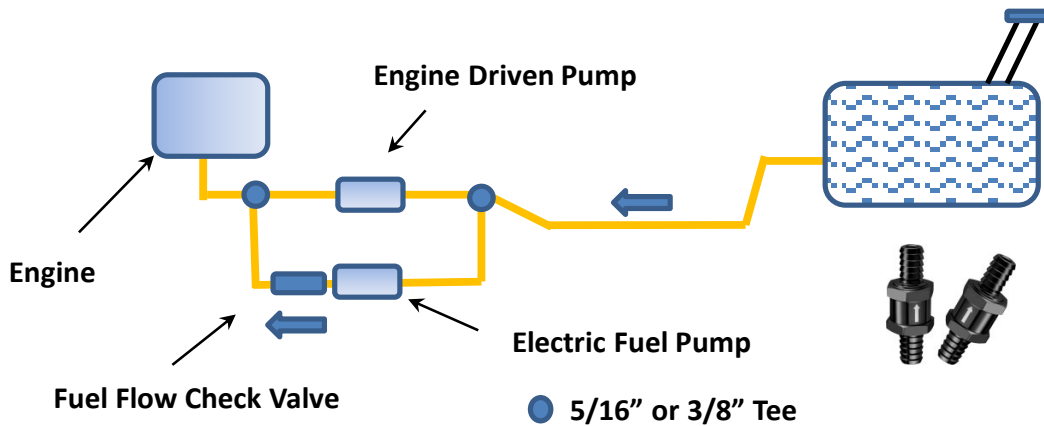

\*Use option (2) for high performance engines.

## ***Classic Thunderbird Maintenance Tech-Tips Cont.***

### **Option (1) Electric Fuel Pump Installation On 1957 Thunderbird**



Send your question to my email address and I will post the question/answer in next month's newsletter. \*Also, any suggestions you have for future tech-tips.

	
	<b>Rick Charniga</b> <b>Technical Director</b>
<b>P.O. Box 51027</b> <b>Livonia, MI 48151</b>	<b>734.740.3556</b> <b>rickcharniga@gmail.com</b>

\* Next month's tech-tip is maintaining your Thunderbird's brake system.

# The Michigan Central Train Station

## McShanes Irish Pub







An Irish Pub & Whiskey Bar located in Detroit's oldest neighborhood featuring a huge beer garden, free safe secured parking with free shuttle service to all downtown events.



An Irish-American Sports bar located in the heart of the Motor City.



Featuring a huge selection of Michigan craft beer and not so traditional bar fare ranging from signature Irish Egg Rolls, Shepherds Pie to the best Wings and macaroni & cheese in the city.





# 70th Anniversary Pin

While Supplies Last!  
**\$10.00** each

Celebrating the  
**Thunderbird**



**Order Today!** Mail check and indicate quantity to:  
Water Wonderland Thunderbird Club  
P.O. Box 51027  
Livonia, MI 48151

Pin size 1.25" w ◦ Supporting our scholarship program ◦ 586-703-4435

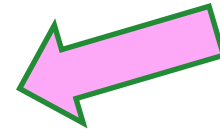

## Who Owned Your Car?

Curious? Vehicle title history records are available by mail for \$15.00, or \$16 if certified. To request a copy of your vehicle's record, complete the [Record Lookup Request form](#) online and return with payment made out to State of Michigan to the address on the form. You can also email me at [barry.burnham@me.com](mailto:barry.burnham@me.com) and request a form to mail in.



Have you checked out our brand new website?

# Michigantbirds.org

Please let me know what you think too!



# Executive Board

**Barry Burnham, President**  
586-703-4435  
[barry.burnham@me.com](mailto:barry.burnham@me.com)

**Keith Bentley, Vice President**  
734-812-5404  
[klbentley01@yahoo.com](mailto:klbentley01@yahoo.com)

**Nancy Burnham, Secretary**  
586-747-6805  
[nburnham1152@gmail.com](mailto:nburnham1152@gmail.com)

**Pam Bentley, Treasurer**  
734-812-4781  
[pcbentley21@yahoo.com](mailto:pcbentley21@yahoo.com)

## Directors

**Rick Charniga, Technical Director**  
734-740-3556  
[rickcharniga@gmail.com](mailto:rickcharniga@gmail.com)

**David Lau, Technical Director**  
734-358-6071  
[toomanycars@charter.net](mailto:toomanycars@charter.net)

**Denise Sikora, Membership Director**  
313-719-1588  
[56tbird@sbcglobal.net](mailto:56tbird@sbcglobal.net)

## Standing Committees

**Nancy Seyfarth, Event Coordinator**  
313-436-8327  
[nancyouseyfarth@gmail.com](mailto:nancyouseyfarth@gmail.com)

**JoAnn Rodriguez, Event Reservations**  
248-719-0160  
[joannbill801@comcast.net](mailto:joannbill801@comcast.net)

**David Campbell, Transition Team**  
248-464-1597  
[hzvggg@charter.net](mailto:hzvggg@charter.net)

**Larry Seyfarth, Advisor**  
313-436-8327  
[larryseyfarth@yahoo.com](mailto:larryseyfarth@yahoo.com)

**Don't Wait Any Longer!**  
Pick an event, get your Tbird  
ready and join us!



*Happy Easter!*



**Barry Burnham, Newsletter**  
586-703-4435  
[barry.burnham@me.com](mailto:barry.burnham@me.com)